



Pressure Tanks

ASME Code Stainless Steel & Galvanized

Binks. The right tank for every application.

Over 100 years
of spray finishing
leadership.



Since 1890, when it introduced its first cold water paint-spraying machine, Binks has provided the world with

Table of Contents

Binks	2
Getting the most from Binks tanks	3
PT ASME Code Tanks	4, 5
Stainless Steel Tanks	6, 7
Galvanized Tanks	8, 9
Large Capacity Galvanized Tanks	10
Tank Accessories	11

superior spray finishing technology. In addition to spray guns, Binks also offers a complete line of pressure tanks and accessories.

Our stainless steel, galvanized and zinc-plated tanks are designed for use with the full range of today's coatings—including waterbornes. For easy clean up, we also offer disposable, reusable tank liners. In addition, our product line includes a complete line of accessories and special products.



Binks tanks and accessories are built to the highest quality standards. And many specific products are ASME and registered with CRN (Canada) to meet the requirements of today's global marketplace. In addition to the products offered in this brochure, we will continue to

support older Binks tanks and accessories with service parts.

Our team of experts – engineers, designers, technicians, and our customer service group are constantly working to bring you the quality, efficiency, performance and value you expect from one of the world's most recognized spray finishing brands.

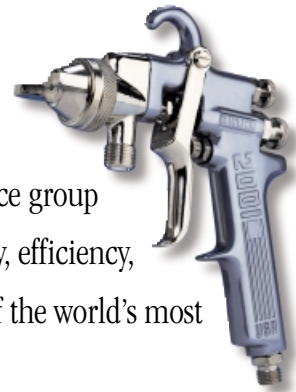

Insist on Binks. Why settle for less?



Getting the Most from Binks Tanks

The Importance of Code Certified Tanks

ASME "code" or "coded" tanks are built to rigid engineering and manufacturing standards set by the American Society of Manufacturing Engineers (ASME). The ASME code, as it relates to pressure vessels attached to spray gun nozzles, is primarily concerned with the use of flammable materials and also covers applications where a tank is used in an OSHA-regulated environment. To comply with OSHA regulations, and if you are using a flammable material at greater than 15 PSI and your local fire department has adopted NFPA 33, you must use an ASME code tank. Refer to NFPA 33, standard for spray application using flammable or combustible materials.

When to Use Pressure Tanks

Binks tanks provide an economical means of supplying paint and offer a uniform rate of flow at constant pressure. When combined with the use of disposable liners, tanks are the most economical method for most applications. When considering the alternative of using pumps, factor in maintenance and repair expenses because pumps, with their mechanical moving parts, are subject to wear.

As a general rule of thumb, if your paint operation uses less than 15 gallons of paint per shift, you probably should use tanks. For higher-volume operations, pumps may be more economical because the time spent re-filling tanks would exceed the savings you'd get with them. Binks manufactures and markets both tanks and pumps and your Binks Finishing Specialist can help you figure the best alternative for your operation.

Waterborne Coatings

The major reason for using waterborne coatings is their low Volatile Organic Compound (VOC) content. In many installations this results in compliance with EPA emission limits. Other advantages of waterborne coatings include reduced fire hazards and lower toxicity.

Spray equipment and spray techniques are similar to those for solvent-borne applications. When spraying waterborne coatings, corrosion resistant materials are recommended for application equipment, and surfaces to be coated must be meticulously clean.

Corrosion Proof Components

To avoid corrosion-contamination of waterborne coatings, use application equipment and components composed of 300 grade stainless steel or non-corroding plastics. Spray guns should have stainless steel fluid passages, fluid nozzles and needles. Positive displacement pumps should have stainless steel cylinders, ball checks and seats. Diaphragm pumps should be non-rusting acetal. Pressure tanks should be all stainless or stainless steel fitted and should be used with a disposable liner. Material handling components, such as fluid regulators, filters and agitators should be stainless steel. Hose and tubing connections and fittings should be stainless steel or nylon.

Uniform Fluid Flow

Compared to pumps, tanks generally provide a more uniform rate of fluid flow at constant pressure. Although the difference may be unnoticeable with most materials, highly viscous products such as glues may be more uniformly applied when the material is supplied from a pressure tank.

Other System Considerations

Waterborne coatings are shear sensitive to being stirred or pumped. This can have a degradation effect on some waterborne coatings. Accordingly, Binks tanks exhibit low shear characteristics. A reciprocating agitator is recommended to keep pigments in suspension without degrading the material. Fluid regulators and filters should also be low shear.

Waterborne coatings also evaporate very slowly. Heated flash zones may be required to remove enough of the water prior to the product entering the oven to avoid popping and boiling of the water. Spray booths and oven surfaces should be galvanized or protected against corrosion. Ovens work more efficiently when ventilated to remove excess humidity.

With the typical rotary agitation, the whirlpool motion creates a cavitation and shear with some materials around the center of the shaft. This cavitation leads to trapped air with waterborne materials.

The entrapped air bubbles in the fluid can be avoided by using a reciprocating agitator motor. Its back-and-forth (rather than circular) motion is significantly less likely to create bubbles in the mix, and entrapment is virtually eliminated.

A Binks Finishing Specialist will help you select the right components or design a complete system for you. For local assistance call 1-888-992-4657.



ASME or "coded" tanks are built to rigid engineering and manufacturing standards set by the American Society of Manufacturing Engineers (ASME). The ASME code, as it relates to pressure vessels attached to spray gun nozzles, is primarily concerned with the use of flammable materials and also covers applications where a tank is used in an OSHA-regulated environment. If you are using a flammable material, at greater than 15 PSI and your local fire department has adopted NFPA 33, you must use an ASME code tank. Refer to NFPA 33, standard for spray application using flammable or combustible materials.



PT ASME Code Tanks

New-Economical

ASME certification makes the Binks PT Series the only code PT tanks available in the marketplace that meet OSHA regulations for using flammable and combustible materials.



Binks new stainless and zinc ASME certified PT Series Tanks are economical and designed for use with waterborne and flammable materials that can be applied at less than 80 PSI.

All PT Series tanks feature a 2.8 gallon capacity and low profile tank design which accepts U.S. and Canadian one-gallon pails.



Zinc Plated for Solvent-Based Coatings



Ideal for solvent-based coatings. Optional disposable tank liner. Zinc plated lid and all wetted parts in lid assembly including: fluid tube, lid bushing, outlet elbow and fitting, and agitator shaft. Zinc plated tank shell.

Stainless Steel and Zinc for Waterborne Coatings



Ideal for waterborne coatings when used with a disposable tank liner. 300 grade stainless steel lid and all wetted parts in lid assembly including: fluid tube, lid bushing, outlet elbow and fitting, and agitator shaft. Zinc plated tank shell.

Zinc Plated Lid and Tank Shell

Zinc Plated Throughout, Including Lid, Wetted Parts, and Tank Shell

AIR REGULATION	FLUID AGITATION	UP TO 2.8 GAL 83C
Single Reg	No Agitation	83C-210
Double Reg	No Agitation	83C-220
Single Reg	Std. Agitation (D)	83C-211
Double Reg	Std. Agitation (D)	83C-221
Disposable Liner		PT-78-K60
Service Bulletin		SBBI-21-044

(D) =Direct Drive Agitator: Uses direct mount Air Mount and air adjusting valve.
NOTE: The air regulator(s) and gauge(s) are shipped inside the tank to prevent damage in shipping. Service Bulletin SBB1-21-044

Stainless Steel Lid & Zinc Plated Tank Shell

Stainless steel lid, including all wetted parts; tank shell is zinc plated

AIR REGULATION	FLUID AGITATION	UP TO 2.8 GAL 83Z
Single Reg	No Agitation	83Z-210
Double Reg	No Agitation	83Z-220
Single Reg	Std. Agitation (D)	83Z-211
Double Reg	Std. Agitation (D)	83Z-221
Disposable Liner		PT-78-K60
Service Bulletin		SBBI-21-043A

(D) =Direct Drive Agitator: Uses direct mount Air Mount and air adjusting valve.
NOTE: The air regulator(s) and gauge(s) are shipped inside the tank to prevent damage in shipping. Service Bulletin SBB1-21-043A

Specifications

Maximum Working Pressure 80 PSI
Fluid Outlet 3/8" NPS
Air Inlet 1/4" NPS

Binks Disposable Tank Liners



For 83C and 83Z Binks tanks use either the 2.8 gallon tank liner PT-78-K10, quantity of 10 liners (1 bag of 10) or use the 2.8 gallon tank liner PT-78-K60, quantity of 60 liners.

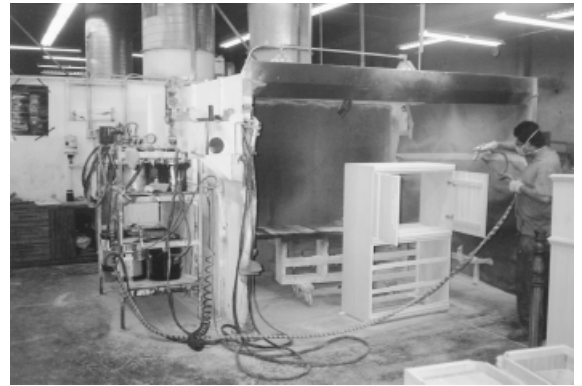

- *Economical*
- *ASME Approved*
- *Complies with OSHA Regulations*
- *Meets NFPA 33 Standards*

Stainless Steel Tanks

Your Best Long-Term Value



All stainless steel tanks and lids are precision crafted of heavy gauge 304 stainless and are electropolished. All models are equipped with a bottom outlet plug. Additionally, these tanks are fitted with 100% stainless steel non-corrosive and non-corroding wetted parts.



Binks stainless steel pressure tanks are designed and built to prevent corrosion-contamination, an inherent problem with waterborne coatings. For maximum cleanliness, use with Binks disposable tank liners.



Binks 9.8 and 11.8-gallon tanks (left) accept standard and imperial 5-gallon shipping pails. 2.8-gallon tanks accept 1-gallon pails.

Binks Stainless Steel Pressure Tanks are suitable for virtually all fluids and solvents. They are ASME certified and permanently labeled for 110 PSIG maximum working pressure.

Tanks and lids are constructed of heavy gauge 304 stainless steel and are electropolished. All models are equipped with top outlet and bottom outlet plug, which can be adapted for bottom outlet.

Additionally, these tanks are fitted with 100% stainless steel non-corrosive and non-corroding wetted parts.

Specifications

Maximum Working Pressure 110 PSI
 Fluid Outlet, Top 3/8" NPS
 Fluid Outlet Plug, Bottom 1" NPT
 Air Inlet 1/4" NPS

Ideal for Waterborne Coatings

Binks Stainless Steel pressure tanks are designed to prevent corrosion-contamination, an inherent problem with waterborne coatings. These tanks are all stainless steel, including fittings, and should be used with a Binks disposable liner for maximum cleanliness. Material handling components, such as fluid regulators, filters and agitators should also be

of stainless steel. We also recommend you use hose and tubing connections/ fittings made of stainless steel or plastic.

Other Considerations

Waterborne coatings are shear sensitive to being stirred or pumped. Stirring and pumping can degrade some waterborne coatings. Binks pumps, however, are designed for extremely low shear characteristics. A Binks oscillating agitator is recommended for keeping pigments in suspension without degrading the material. Binks fluid regulators and filters are also recommended for their minimal low shear characteristics.

Bottom Outlet Conversion Kits

These fittings allow a standard top outlet tank to feed from the bottom by removing the plug in the bottom port. Available in stainless steel only.

TANKS CAPACITY	STAINLESS STEEL PART NO.	SHIP WT.
2.8-GAL	QMS-435	3 LBS.
9.8-GAL	QMS-443	4 LBS.
11.8-GAL	QMS-443	4 LBS.
19.8-GAL	QMS-443	4 LBS.

Stainless Steel

Bottom outlet plug and opening in skirt standard

AIR REGULATIONS	FLUID AGITATION	SMALL TANK (2 GAL.)	MEDIUM TANK (5 GAL.)	LARGE TANK (10 GAL.)	EXTRA LG. TANK (15 GAL.)
		Actual Capacity 2.8 Gallons 83S	Actual Capacity 9.8 Gallons* 83S	Actual Capacity 11.8 Gallons* 83S	Actual Capacity 19.8 Gallons 83S
Single Reg	No Agitation	83S-210	83S-510	83S-1010	83S-1510
Double Reg	No Agitation	83S-220	83S-520	83S-1020	83S-1520
Single Reg	Std. Agitation	83S-211 (D)	83S-513 (I)	83S-1013 (I)	83S-1513
Double Reg	Std. Agitation	83S-221 (D)	83S-523 (I)	83S-1023 (I)	83S-1523
Single Reg	Opt. Agitation	83S-213 (I)	83S-516 (R)	83S-1016 (R)	83S-1516
Disposable Liner		PTL-78-K60	PTL-408-K20	PTL-412-K8	PTL-415-K10
Service Bulletin		SBBI-21-068	SBBI-21-070	SBBI-21-064	SBBI-21-064



When combined with the use of disposable liners, there is no more economical way to run a paint operation for most applications.

For 83S-200 Binks tanks use either the 2.8 gallon tank liner PTL-78-K10, quantity of 10 liners (1 bag of 10) or use the 2.8 gallon tank liner PTL-78-K60, quantity of 60 liners. For 83S-500 Binks tanks use the 9.8 gallon tank liner PTL-408-K20, quantity of 20 liners. For 83S-1000 Binks tanks use the 11.8 gallon tank liner PTL-412-K8, quantity of 8 liners. For 83S-1500 Binks tanks use the 19.8 gallon tank liner PTL-415-K10, quantity of 10 liners.

(D) = Direct Drive Agitator: Uses direct mount Air Mount and air adjusting valve.

(I) = Indirect Drive Agitator: Uses Motor coupled to gearbox for higher torque at lower speeds.

(R) = Reciprocating Agitator: Self-Reversing Air Motor for efficient mixing and reducing cavitation.

* Binks 9.8 and 11.8-gallon tanks accept standard and imperial 5-gallon shipping pails.

NOTE: The air regulator(s) and gauge(s) are shipped inside the tank to prevent damage in shipping.

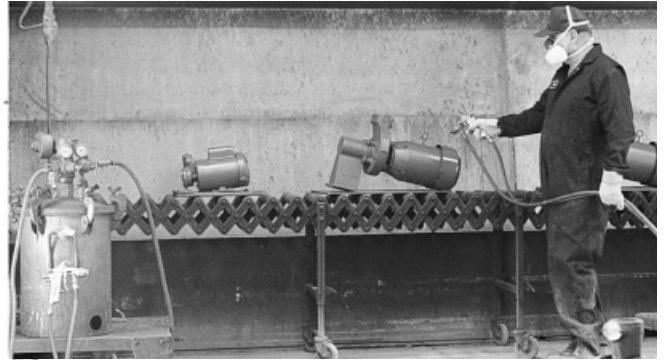

Maximizing finishing productivity in spray booths that use a variety of finishes is easy when multiple Binks tanks are used.



Galvanized Tanks

Ideal For Most Applications



Binks galvanized tanks are built to the highest quality standards. Our team of experts - engineers, designers, technicians and customer service professionals - is constantly working to bring you the quality, efficiency, performance and value you expect from one of the world's most recognized spray finishing brands.

Binks galvanized tanks are primarily used with non-corrosive materials. Constructed with a heavy pressed steel lid and forged steel clamps, galvanized tanks have ports for both bottom and top fluid outlets.



All galvanized tank models are ASME certified for working pressure. Lids disassemble easily-no special tools are required-and all models are easy to service and clean.

Galvanized steel tanks are primarily used with non-corrosive materials. Constructed with a heavy pressed steel lid and forged steel clamps, galvanized tanks are equipped with top outlet and bottom outlet plug, which can be adapted for bottom outlet. The bottom outlet is recommended for heavy, viscous materials such as emulsified asphalts, cut-back asphalts, rubber compounds, etc.

Specifications

Maximum Working Pressure110 PSI
 Fluid Outlet, Top3/8" NPS
 Fluid Outlet Plug, Bottom1" NPT
 Air Inlet1/4" NPS



Binks 11.8-gallon tanks (left) accept standard and imperial 5-gallon shipping pails. 2.8-gallon tanks accept 1-gallon pails.



Bottom Outlet Conversion Kits

These fittings allow a standard top outlet tank to feed from the bottom by removing the plug in the bottom port. Available in stainless steel only.

TANKS CAPACITY	STAINLESS STEEL PART NO.	SHIP WT.
2.8-GAL	QMS-435	3 LBS.
9.8-GAL	QMS-443	4 LBS.
11.8-GAL	QMS-443	4 LBS.
19.8-GAL	QMS-443	4 LBS.

Galvanized Steel

Bottom outlet plug and opening in skirt standard

AIR REGULATIONS	FLUID AGITATION	SMALL TANK (2 GAL.)	MEDIUM TANK (5 GAL.)	LARGE TANK (10 GAL.)	EXTRA LG. TANK (15 GAL.)
		Actual Capacity 2.8 Gallons 83G	Actual Capacity 9.8 Gallons* 83G	Actual Capacity 11.8 Gallons* 83G	Actual Capacity 19.8 Gallons 83G
Single Reg	No Agitation	83G-210	83G-510	83G-1010	83G-1510
Double Reg	No Agitation	83G-220	83G-520	83G-1020	83G-1520
Single Reg	Std. Agitation	83G-211 (D)	83G-513 (I)	83G-1013 (I)	83G-1513
Double Reg	Std. Agitation	83G-221 (D)	83G-523 (I)	83G-1023 (I)	83G-1523
Single Reg	Opt. Agitation	83G-213 (I)	83G-516 (R)	83G-1016 (R)	83G-1516
Disposable Liner		PTL-78-K60	PTL-408-K20	PTL-412-K8	PTL-415-K10
Service Bulletin		SBBI-21-068	SBBI-21-070	SBBI-21-062	SBBI-21-062



When combined with the use of disposable liners, there is no more economical way to run a paint operation for most applications.

For 83G-200 Binks tanks use either the 2.8 gallon tank liner PTL-78-K10, quantity of 10 liners (1 bag of 10) or use the 2.8 gallon tank liner PTL-78-K60, quantity of 60 liners. For 83G-500 Binks tanks use the 9.8 gallon tank liner PTL-408-K20, quantity of 20 liners. For 83G-1000 Binks tanks use the 11.8 gallon tank liner PTL-412-K8, quantity of 8 liners. For 83G-1500 Binks tanks use the 19.8 gallon tank liner PTL-415-K10, quantity of 10 liners.

(D) = Direct Drive Agitator: Uses direct mount Air Mount and air adjusting valve.

(I) = Indirect Drive Agitator: Uses Motor coupled to gearbox for higher torque at lower speeds.

(R) = Reciprocating Agitator: Self-Reversing Air Motor for efficient mixing and reducing cavitation.

** Binks 9.8 and 11.8-gallon tanks accept standard and imperial 5-gallon shipping pails.*

NOTE: The air regulator(s) and gauge(s) are shipped inside the tank to prevent damage in shipping.

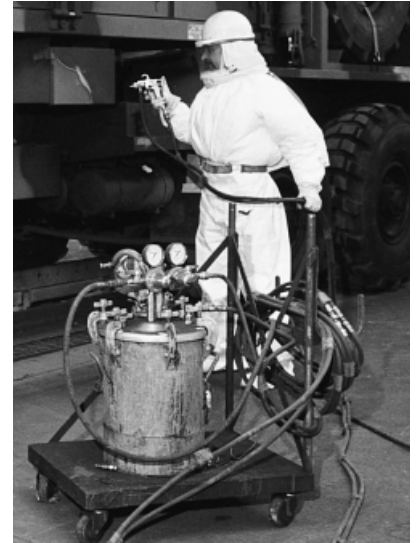

A typical industrial paint "kitchen" utilizes several sizes and types of tanks.



Galvanized and Stainless Steel Fitted Tanks

Large Capacity – 30 and 60 Gallon

Specifications

Maximum Working Pressure110 PSI
 Fluid Outlet, Top 3/8" NPS
 Fluid Outlet, Bottom Opening1" NPT
 Bottom Outlet Kit, Fluid Outlets . . 3/8" NPS
 Air Inlet1/4" NPS

Dual Bottom Outlets

Galvanized

Part no. 83-422930 gallon outlet kit
 Part no. 83-423060 gallon outlet kit

Installing Second Regulator

Large Capacity Tanks require 2 regulators for optimal performance. One regulator controls agitation and the other regulator controls air to the spray gun only.

For maximum value, purchase the following Binks parts:

- 1 Regulator, Part No. 85-200
- 1 Gauge, Part No. 83-1290

Purchase the following parts at your local hardware supplier:

- 1 D.M. Nipple 3/8" NPT x 1/4" NPT
- 1 Plug Square Head 1/4" NPT

Inner Containers

Stainless Steel (Order Separately)

PART NO.	DESCRIPTION
83-1569	30 Gallon - Top Outlet
83-1581	60 Gallon - Top Outlet
83-2229	60 Gallon - Bottom Outlet
83-2230	30 Gallon - Bottom Outlet

Note: Inner containers are shipped installed. Stainless steel dual bottom outlet assembly (83-2155) is part of the bottom outlet inner container. Refer to installation instructions included with inner container.

Standard Galvanized Units

Ideal for most applications

Binks large capacity Galvanized Tanks are ASME certified. They are the best choice when applying large quantities of coatings materials. These 30 and 60 gallon tanks can accommodate multiple spray guns. They are also well-suited to line-stripping operations. These tanks are made of galvanized steel and are primarily used with non-corrosive materials. Constructed with a heavy pressed steel lid and forged steel clamps, galvanized tanks have ports for both bottom and top fluid outlets. The bottom outlet is recommended for heavy, viscous materials such as emulsified asphalts, cut-back asphalts, rubber compounds, etc.

AIR REGULATIONS	FLUID AGITATION	30 GALLON	PART SHEET	60 GALLON	PART SHEET
Single Reg	No Agitation	83-5801	1345	83-5701	1324
Single Reg	With Agitation	83-5807	1347	83-5707	1322

NOTE: All tanks indirect drive agitator uses motor coupled to gearbox for higher torque at low speeds.
 All tanks have 2 top outlets
 All tanks have a plug and opening in skirt for bottom outlet

Stainless Steel Fitted Galvanized Units

Ideal for waterborne and corrosive materials

For use with latex, ceramics, and other corrosive fluid materials. Tank heads are hot tin dipped; shells are galvanized. Inner containers (optional) and all parts that come in contact with material are of stainless steel. Tank models do not include inner containers. Order inner containers separately – as noted below.

AIR REGULATIONS	FLUID AGITATION	30 GALLON	PART SHEET	60 GALLON	PART SHEET
Single Reg	No Agitation	83-5873	1346	83-5773	1323
Single Reg	With Agitation	83-5879	1348	83-5779	1321

NOTE: All tanks indirect drive agitator uses motor coupled to gearbox for higher torque at low speeds.
 All tanks have 2 top outlets
 All tanks have a plug and opening in skirt for bottom outlet

83-2229 (60 Gallon) and 83-2230 (30 Gallon) SS Inner Containers

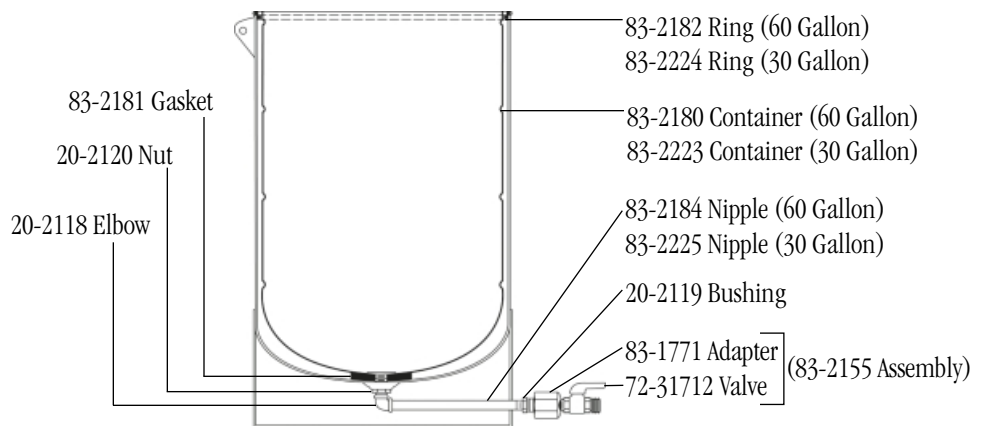

Tank Accessories

Indirect Air Motor Drive



Standard duty, smooth running with gear reducer, 1/4 hp, 15:1 ratio, 20 to 120 RPM. Includes throttling valve, fittings, and hose for connection to air supply on tank lid. Air consumption: Approximately 6 CFM @ 50 RPM. Model QS-5012. For 2.8, 11.8 & 19.8 gallon tanks only. Service Bulletin SB-19-087-4.

Reciprocating Air Motor Drive

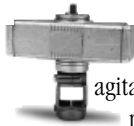

Slow 180-degree back-and-forth action ensures excellent agitation. Uses 50% less air than rotary type air motors. 168 in.-lbs., torque at 60 psi. Air consumption: Approximately 3.0 CFM @ 60 psi. The Binks Reciprocating Air Motor Drive features a wide adjustment range of 1 to 40 strokes per minute. It virtually eliminates trapped air, and shear-sensitive coatings are not affected by its gentle yet effective agitation. Model QSR-503. For 2.8, 11.8 & 19.8 gallon tanks only. Service Bulletin SB-19-222-B.

Agitator Drives

Standard Model 31-116



Air Motor Drive Unit with gear reducer. 1/2 H.P., 20:1 Ratio, 15 to 90 RPM output.

Shipping weight 20 lbs.

Part Sheet 1214. For 30 & 60 gallon tanks only.

Model 31-237



Oscillating Air Motor. 1-70 oscillations / min. 400 inch lbs. Torque at 80 psi.

Shipping weight 15 lbs.

Part Sheet 2014. For 30 & 60 gallon tanks only.

Heavy Duty Model 83-2476



Air Motor Drive Unit with gear reducer. 1 H.P., 30:1 Ratio, 15 to 50 RPM output.

Shipping weight 20 lbs.

Part Sheet 1622. For 30 & 60 gallon tanks only.

Direct Drive Agitator



Air-powered direct drive agitator assembly with 1/4 hp air motor and a three-bladed propeller to keep materials mixed in suspension, even high solids. Use on two gallon models.

Must order air motor and shaft separately.

83Z SERIES STAINLESS STEEL

Model PT-427—air motor

Model PT-419—shaft assembly

83C SERIES ZINC PLATED

Model PT-418—air motor

Model PT-428—shaft assembly

83S AND 83G SERIES

Refer to part sheets on tank

Air Regulator Assembly Kits



Model QMS-436: One gauge, one regulator. Converts single regulation to dual.

Model QMS-4006: One gauge, one regulator. Regulates and indicates tank pressure.

Model QMS-4007: Two gauges, two regulators. Controls tank pressure and atomization air pressure to gun.

Model HAR-511: Regulator only (for fluid pressure).

Model HAR-507: Second regulator for tanks with one regulator.

Model 83-1290: Gauge only, range 0-150 psi (for fluid).

Model 83-2727: Gauge only, range 0-100 psi (for air).

Refer to the pressure tank service bulletin for service instructions.

Premium Spray Finishing Air Hose Assemblies and Connections

SIZES I.D.	LENGTH OF HOSE	HOSE ASSEMBLY PART NO.	BULK HOSE NUMBER	CONNECTION THREAD SIZE	TYPE OF CONNECTION	CONNECTION PART NUMBER
5/16"	25 ft.	71-1205	71-11000	1/4" NPS (F)	three piece reusable	72-1317
5/16"	50 ft.	71-1206	71-11000	1/4" NPS (F)	three piece reusable	72-1317
3/8"	25 ft.	71-1355	71-12000	1/4" NPS (F)	three piece reusable	72-1325
3/8"	50 ft.	71-1356	71-12000	1/4" NPS (F)	three piece reusable	72-1325

Fluid All™ Fluid Hose Assemblies and Connections

SIZES I.D.	LENGTH OF HOSE	HOSE ASSEMBLY PART NO.	BULK HOSE NUMBER	CONNECTION THREAD SIZE	TYPE OF CONNECTION	CONNECTION PART NUMBER
3/8"	25 ft.	71-3303	71-282	3/8" NPS (F)	three piece reusable	72-1328
3/8"	50 ft.	71-3304	71-282	3/8" NPS (F)	three piece reusable	72-1328

Lid Gaskets

GASKET MATERIAL PART NO.	2.8-GAL GALV. OR S.S. PART NO.	11.8 GAL. GALV. OR S.S. PART NO.	19.8 GAL. GALV. OR S.S. PART NO.	2.8 GAL. P.T. TANK PART NO.	30 GAL. GALVANIZED PART NO.	60 GAL. GALVANIZED PART NO.
Santoprene®	QMS-80-1	QM-1458-1	QM-1458-1	PT-33-1	—	—
Thiokol®	—	—	—	—	83-2120	83-2122
Rubber	—	—	—	—	83-2121	83-2123

Binks now offers Santoprene® lid gaskets in place of the standard Thiokol® gasket. Injection molded of new hi-tech materials, Santoprene is highly chemical resistant.

Sales and Service
Through a Nationwide Network of Industrial Distributors



North American Office

ITW Industrial Finishing
Binks
195 Internationale Blvd.
Glendale Heights, IL 60139
630-237-5000
Fax 630-237-5011
www.binks.com

Customer Service
1-800-992-4657

Technical Support
1-888-992-4657

